

USB-i485

USB ↔ RS485/RS422 Converter

INSTRUCTION MANUAL



5000466 V1.0x A

INTRODUCTION

The **USB-i485** module is a cost-effective way to convert RS485 or RS422 industrial buses to a USB interface. When connected to a PC USB port the **USB-i485** module is automatically detected and is installed as a native COM port, which is compatible with any existing serial communication application.

Multiple modules can be installed when using USB hubs thus allowing a hassle-free configuration of a multi serial system without any IRQ or DMA configuration. 1500 Vdc isolation between the USB port and RS485/RS422 protects the PC from spikes or possible misconnections in the communication bus.

SPECIFICATIONS

The **USB-i485** converter can be configured for four-wire (Full Duplex) RS422 and RS485 or two-wire (Half Duplex) networks. When operating in two-wire RS485 the data transfer control is automatically done by the converter. Two independent and isolated RS485 networks can be supported by one **USB-i485** module thus duplicating the possible number of remote devices.

- Computer interface: USB V1.1 Plug and Play.
- Operational system virtual serial port driver. Supports Windows 7/Vista/XP/2008Server/2003Server/98/ME/2000/CE, MAC & Linux 2.4.20 or above.
- Field Interfaces: RS485 Half Duplex (dual buses), RS485 Full Duplex or RS422.
- Jumper selected RS485 / RS422.
- Automatic flow control for RS485 Half Duplex.
- 120 Ohms internal resistors termination enabled by jumpers.
- Data rate: from 300 bps to 250 kbps.
- Maximum RS485/RS422 cable length : 1200 m
- Maximum number of devices in the RS485 network (unit load devices – 12 kΩ):
Half Duplex: 2 x 32 devices
Full Duplex: 32 devices
- Data transmission and reception LED indicators
- Power: from the USB port. Consumption: <100 mA.
- Isolation: 1500 Vdc (1 minute) from USB interface and the RS485/RS422 interface.
- RS485/422 bus protection: ±60 Vdc, 15 kV ESD.
- USB connection: Mini-B connector. A 1.5 m cable with plugs mini-B and A is provided with the module.
- RS485/422 connector: screw terminal type accepting 1.5 mm² (16 AWG) wires.
- Operating environment: 0 to 50°C, 10 to 90% relative humidity, non-condensing.
- ABS enclosure: 70 x 60 x 18 mm

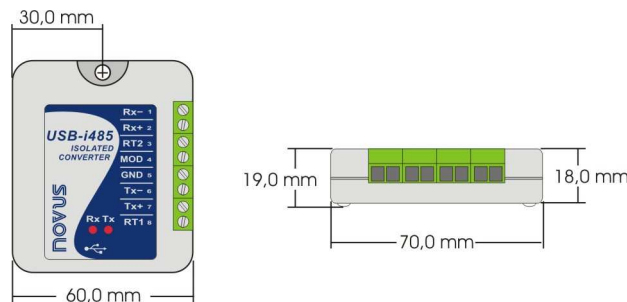

USB DRIVER INSTALLATION

The following installation steps may be slightly different depending on your PC configuration and Windows version. Follow the Wizard instructions and use the following steps and figures to select the correct installation options.

WINDOWS 98 / ME / 2000

1. Insert the **USB-i485** CD in the CD-ROM drive.
2. Connect the module to a PC USB port. Windows® will detect the new hardware and after a few seconds the Add New Hardware Wizard will start. Select "Next".
3. Select "Search for the best driver for your device (Recommended)" and select "Next".
4. Select option "CD-ROM drive". If the installation files are not in a CD, select option "Specify a location" and type the path for the required files. Select "Next".
5. Select "Next" when Windows® is ready to install the driver.
6. The **USB-i485** driver files will be copied to your computer and, when concluded, a window will show up informing that the wizard has finished installing the software. Select "Finish".
7. It is possible that the previous steps repeat a second time for the completion of installation.

In future connection of **USB-i485** modules, it is possible that Windows® prompt again for the USB driver installation. In this case, the same wizard will be presented. Follow the above steps, but check no options in step 4, since the driver files are already in your computer.

The following figures are examples of Windows 98® Add New Hardware Wizard. For Windows ME® and 2000® they look different, but the information is the same.



WINDOWS XP

1. Insert the **USB-i485** CD in the CD-ROM drive.
2. Connect the module to a PC USB port. Windows® will detect the new hardware and after a few seconds the new hardware wizard will start.
3. The Found New Hardware Wizard will show-up and ask if you want to connect to Windows Update to get the driver. Select the “No, not this time” and select “Next”.
4. Select “Install from a list or specific location (advanced)” and select “Next”.
5. Select “Search for the best driver in these locations” and check option “Search removable media”. Select “Next”. If the installation files are not in a CD, select option “Include this location in the search” and type the path for the required files.
6. If a warning message regarding Windows® XP compatibility appears, select “Continue Anyway”.
7. The **USB-i485** driver files will be copied to your computer and, when concluded, a window will show up informing that the wizard has finished installing the software. Select “Finish”.
8. It is possible that the previous steps repeat a second time for the completion of installation.

In future connection of **USB-i485** modules, it is possible that Windows® prompt again for the USB driver installation. In this case, the same wizard will be presented. Follow the above steps, but select option “Install the software automatically (recommended)”, since the driver files are already installed.

The following figures are examples of Windows XP® New Hardware Wizard.

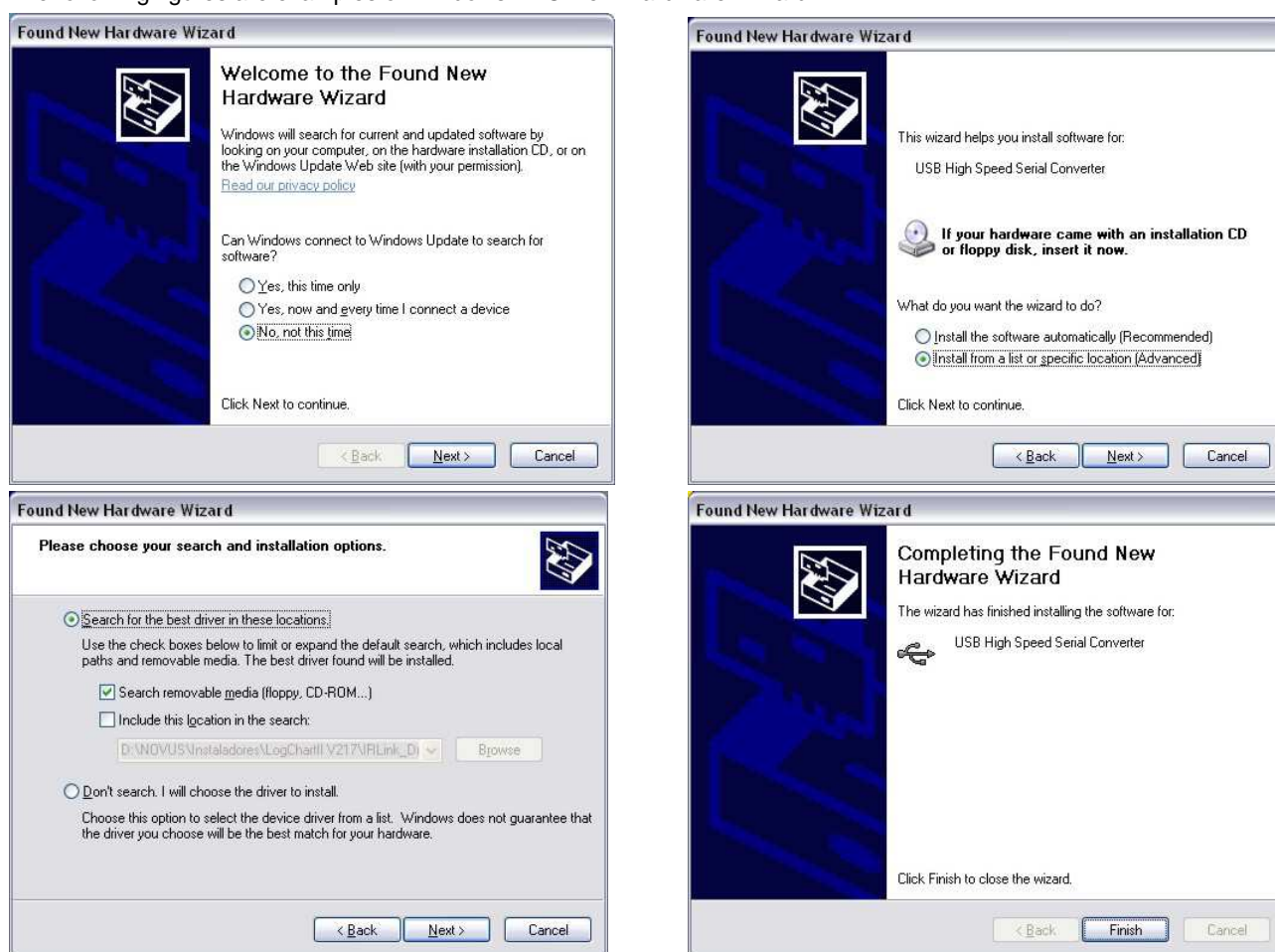

LINUX

Since version 2.4.20, the necessary driver for the converter to work properly is already included in kernel. Once you connect the converter to a PC USB port, the following modules should be loaded (they must be in the kernel list of modules):

- `ftdi_sio` (specific driver of the converter)
- `usbserial` (generic driver for USB-Serial conversion)
- `usbcore` (basic driver for USB devices)

MAC

Installation instructions are included in the **USB-i485** CD-ROM.

SERIAL PORT (COM PORT) ASSIGNMENT – WINDOWS

A few seconds after connection of the **USB-i485**, Windows operating system assigns a COM port number for communication. The assigned COM port number will not change in future connections to the same USB port. Users can easily identify and modify the assigned COM port in:

Control Panel / System / Hardware / Device Manager / Ports (COM & LPT)

Select the desired “USB Serial Port” device, click with the right mouse button and select “Properties”. Select “Port Settings” and click on the “Advanced...” button. In “COM Port Number” list, select the serial port to be assigned. Some serial port can be marked as “in use”. Only select one of these ports if you are sure it is not being used by any other peripheral in your computer.

In some cases, serial port can be marked as “in use” even when the associated device is not in the computer. In this case, it is safe to assign this port to an **USB-i485**.

The following figures illustrate the most important steps for this procedure.

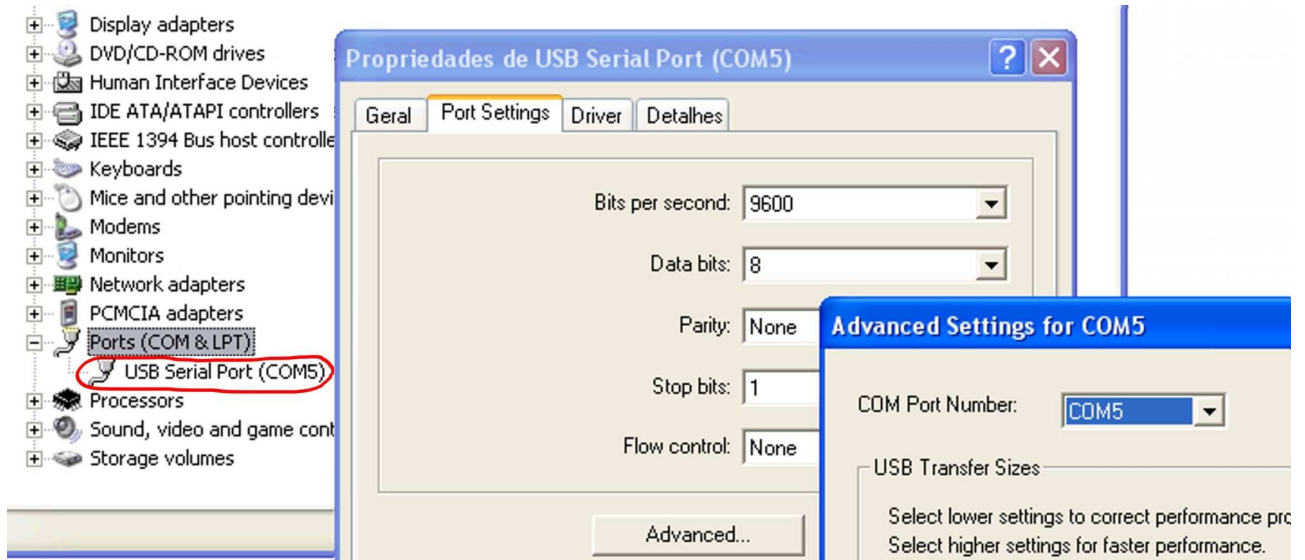

CONNECTIONS

The appropriate connection to the **USB-i485** depends on the type of serial network: RS422, 2-wire RS485 or 4-wire RS485. The following figure shows a description of all **USB-i485** connection terminals.

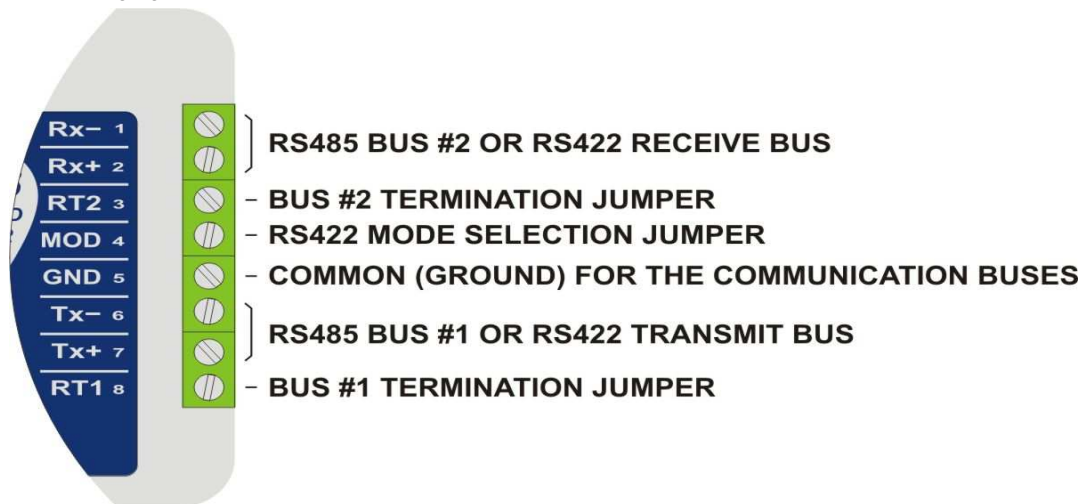

A shielded twisted-pairs cable is recommended for wiring the communication bus from the converter to all network devices. The shield should be grounded and/or connected to the common terminals of all devices. The minimum recommended wire gauge is 24 AWG (0,2 mm²).

Use of a wire connecting all devices common terminals is highly recommended. Damage of the networked devices may result if this recommendation is not followed.

RS485 or RS422 devices from different vendors or of different models may identify the communication terminals using distinct notation. The following table shows some of this notations and its equivalence to the **USB-i485**.

USB-i485 CONNECTION IDENTIFICATION	Rx+ ou Tx+	Rx- ou Tx-
POPULAR RS485 AND RS422 CONNECTION IDENTIFICATION	D	\bar{D}
	D1	D0
	B	A
	D+	D-

HALF-DUPLEX RS485 (2 WIRES)

To set this mode of operation, the MOD terminal (pin 4) must be left unconnected.

This is the usual RS485 connection. A single twisted pair is used for data transmission and reception. Multiple RS485 devices are connected in a single bus, as shown in the next figure. Devices from different vendors may use different names for the data signal terminals. In the following figure, different identification schemes are presented for each device, with the proper connection to the **USB-i485**. RS485 devices can be connected to either bus 1 or 2.

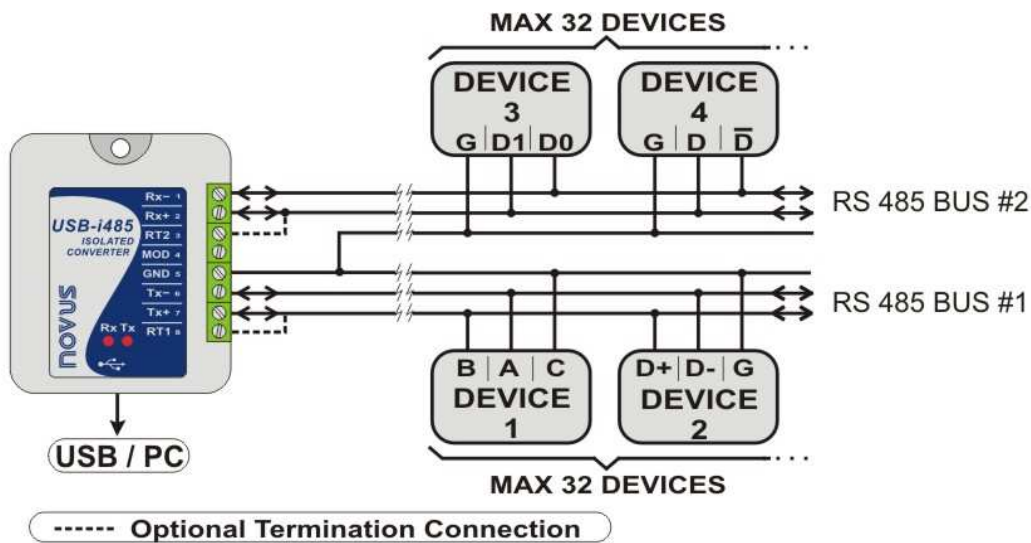

The common terminal (GND – pin 5) must be connected to the corresponding terminals of all network devices, to ensure the same potential in all devices. If a common wire is not connected to all devices, all must be properly grounded according to the manufacturer recommendation. For the **USB-i485**, the proper grounding terminal is pin 5 (GND).

The need to install termination resistors depends on the total length of the communication bus and the communication speed (baud rate). The **USB-i485** has built-in termination resistors, which can be installed by wiring terminals RT1 (8) or RT2 (3) as shown in dashed lines in the last figure. For additional information in grounding, common wire and termination resistors, read the document *RS485 & RS422 Basic*, available on the CD provided with this product and also at www.novusautomation.com for download.

FULL-DUPLEX RS485 (4 WIRES)

To set this mode of operation, the MOD terminal (pin 4) must be connected to terminal GND (pin 5).

In this mode two pairs of wires are used. Data from the **USB-i485** to the networked devices are transmitted through one pair, and the other pair carries data from the devices to the **USB-i485**. Multiple devices are connected as shown in the next figure.

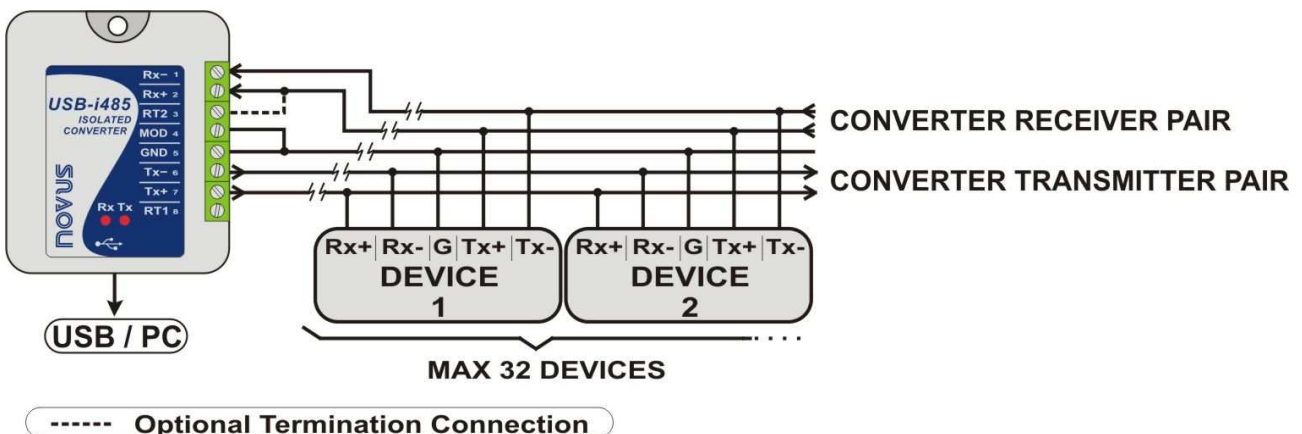

The common terminal (GND – pin 4) must be connected to the corresponding terminals of all network devices, to ensure the same potential in all devices. If a common wire is not connected to all devices, all must be properly grounded according to the manufacturer recommendation. For the **USB-i485**, the proper grounding terminal is pin 5 (GND).

The need to install termination resistors depends on the total length of the communication bus and the communication speed (baud rate). The **USB-i485** has a built-in termination resistor, which can be installed by wiring terminal RT2 (3) as shown in dashed lines in the last figure.

For additional information in grounding, common wire and termination resistors, read the document *RS485 & RS422 Basics*.

RS422

Full-Duplex RS485 specification supersedes RS422. The same connection instructions shown for Full-Duplex RS485 apply for RS422 connection.

CONFLICTS WITH OTHER USB DEVICES UNDER WINDOWS

Installation of the USB driver for the USB-i485 converter may result in conflicts with existing USB devices in the computer (mouse or other Serial/USB devices, for example). In this case, follow the procedure below to restore functionality of the affected device:

Go to the Windows Control Panel and open the USB-i485 converter properties in:

Control Panel / System / Hardware / Device Manager / Ports (COM & LPT)

Select the desired “USB Serial Port” device, click with the right mouse button and select “Properties”. Select “Port Settings” and click on the “Advanced...” button. Uncheck the “Serial Enumerator” option.

Serial Enumerator