



N1040 Controller

TEMPERATURE CONTROLLER – INSTRUCTIONS MANUAL – V1.1x D

SAFETY ALERTS

The symbols below are used on the equipment and throughout this document to draw the user's attention to important operational and safety information.

CAUTION: Read the manual thoroughly before installing and operating the equipment.	CAUTION OR DANGER: Electrical shock hazard

All safety related instructions that appear in the manual must be observed to ensure personal safety and to prevent damage to either the instrument or the system. *If the instrument is used in a manner not specified by the manufacturer, the protection provided by the equipment may be impaired.*

INSTALLATION / CONNECTIONS

The controller must be fastened on a panel, following the sequence of steps described below:

- Prepare a panel cut-out of 46 x 46 mm;
- Remove the mounting clamps from the controller;
- Insert the controller into the panel cut-out;
- Slide the mounting clamp from the rear to a firm grip at the panel.

ELECTRICAL CONNECTIONS

Fig. 01 below shows the electrical terminals of the controller:

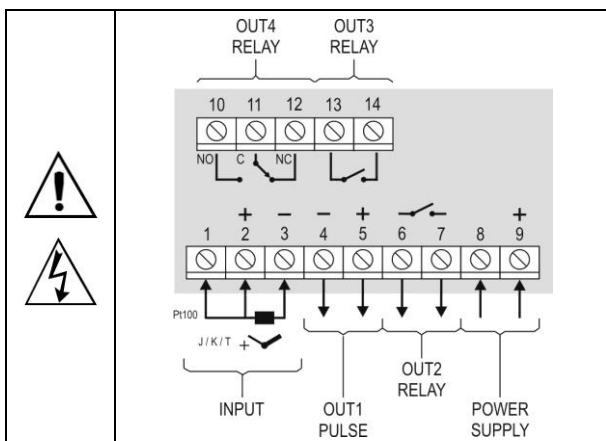

Fig. 01 - Connections of the back panel

RECOMMENDATIONS FOR THE INSTALLATION

- All electrical connections are made to the screw terminals at the rear of the controller.
- To minimize the pick-up of electrical noise, the low voltage DC connections and the sensor input wiring should be routed away from high-current power conductors. If this is impractical, use shielded cables. In general, keep cable lengths to a minimum.
- All electronic instruments must be powered by a clean mains supply, proper for instrumentation.
- It is strongly recommended to apply RC'S FILTERS (noise suppressor) to contactor coils, solenoids, etc. In any application it is essential to consider what can happen when any part of the system fails. The controller features by themselves can not assure total protection.

FEATURES

INPUT TYPE SELECTION

Table 01 shows the sensor types accepted and their respective codes and ranges. Access the parameter **TYPE** in the INPUT cycle to select the appropriate sensor.

TYPE	CODE	RANGE OF MEASUREMENT
Thermocouple J	J	Range: -110 to 950 °C (-166 to 1742 °F)
Thermocouple K	K	Range: -150 to 1370 °C (-238 to 2498 °F)
Thermocouple T	T	Range: -160 to 400 °C (-256 to 752 °F)
Pt100	Pt	Range: -200 to 850 °C (-328 to 1562 °F)

Table 01 – Input types

OUTPUTS

The controller offers two, three or four output channels, depending on the loaded optional features. The output channels are user configurable as **Control Output**, **Alarm 1 Output**, **Alarm 2 Output**, **Alarm 1 OR Alarm 2 Output** and **LBD (Loop Break Detect) Output**.

- OUT1** - Logical pulse, 5 Vdc / 25 mA, available at terminals 4 and 5.
- OUT2** - Relay SPST-NA, 1.5 A / 240 Vac, available at terminals 6 and 7.
- OUT3** - Relay SPST-NA, 1.5 A / 240 Vac, available at terminals 13 and 14.
- OUT4** - Relay SPDT, available at terminals 10, 11 and 12.

CONTROL OUTPUT

The control strategy can be **ON/OFF** (when **Pb = 0.0**) or **PID**. The PID parameters can be automatically determined enabling the auto-tuning function (**Autun**).

ALARM OUTPUT

The controller contains 2 alarms that can be directed (assigned) to any output channel. The alarm functions are described in **Table 02**.

oFF	Output is not used as alarm.	
Lo	Alarm of Absolute Minimum Value. Triggers when the value of measured PV is below the value defined for alarm <i>Setpoint</i> .	
Hi	Alarm of Absolute Maximum Value. Triggers when the value of measured PV is above the value defined for alarm <i>Setpoint</i> .	
dIF	Alarm of Differential Value. In this function the parameters SPA1 and SPA2 represent the deviation of PV in relation to the SP of CONTROL.	
	<div style="display: flex; justify-content: space-around;"> <div style="text-align: center;"> <p>Positive SPA1</p> </div> <div style="text-align: center;"> <p>Negative SPA1</p> </div> </div>	
dIFL	Alarm of Minimum Differential Value. It triggers when the value of PV is below the defined point by (using the Alarm 1 as example).	
	<div style="display: flex; justify-content: space-around;"> <div style="text-align: center;"> <p>Positive SPA1</p> </div> <div style="text-align: center;"> <p>Negative SPA1</p> </div> </div>	
dIFH	Alarm of Valor Maximum Differential Value. Triggers when the value of PV is above the defined point by (using Alarm 1 as example):	
	<div style="display: flex; justify-content: space-around;"> <div style="text-align: center;"> <p>Positive SPA1</p> </div> <div style="text-align: center;"> <p>Negative SPA1</p> </div> </div>	
iErr	Sensor Break Alarm. Activated when the input signal of PV is interrupted, out of the range limits or Pt100 in short-circuit.	

Table 02 – Alarm functions

Note: Alarm functions on **Table 02** are also valid for Alarm 2 (SPA2).

INITIAL BLOCKING OF ALARM

The **initial blocking** option inhibits the alarm from being recognized if an alarm condition is present when the controller is first energized (or after a transition from run YES → NO). The alarm will be enabled only after the occurrence of a non alarm condition followed by a new occurrence for the alarm.

The initial blocking is useful, for instance, when one of the alarms is configured as a minimum value alarm, causing the activation of the alarm soon upon the process start-up, an occurrence that may be undesirable.

The initial blocking is disabled for the sensor break alarm function.

OFFSET

Allows fine adjustments to the PV reading for compensation of sensor error.

FUNÇÃO LBD – LOOP BREAK DETECTION

The parameter defines a time interval, in minutes, within which the PV is expect to react to a control output signal. If the PV does not react properly within the time interval configured in **Lbdt**, the controller interprets this as a control loop break and signals this occurrence in the display.

A LBD event may be sent to any output channel. Simply configure the LBD function to the desired output channel (OUT1 or OUT2): the

selected output will be activated when a LDB condition is detected. When the **Lbdt** parameter is programmed with 0 (zero), the LDB function is disabled.

The LBD is useful in detecting system failures, such us defective sensors or actuators, loads and power supply, among others.

SAFE OUTPUT VALUE WITH SENSOR FAILURE

This function defines an output value (user defined) to be assigned to the control output in the event of a sensor failure.

When the input sensor is identified as broken, the controller switches the control mode to MANUAL while forcing MV to assume the user configured value in the **iEou** parameter. This function requires that one of the alarms be configured as **iErr** and the **iEou** parameter (control output percentage) programmed with a value other then 0 (zero).

Once this function is triggered, the controller remains in SAFE mode (MANUAL control output) even after the sensor failure appears to be fixed. The operator intervention is required for switching back to AUTO mode.

iEou values are only 0 and 100 % when in ON/OFF control mode. For PID control mode any value in the range from 0 to 100 % is accepted.

OPERATION

The controller's front panel, with its parts, can be seen in the **Fig. 02**:



Fig. 02 - Identification of the parts referring to the front panel

Display of PV / Programming (top display, red color): Displays the current value of PV (*Process Variable*). When in configuration mode, it shows the parameters names.

Display of SP / Parameters (bottom display, green color): Displays the value of SP (*Setpoint*). When in configuration mode, it shows the parameters values.

TUNE Indicator: Stays ON while the controller is in tuning process.

OUT Indicator: For relay or pulse control output; it reflects the actual state of the output.

A1 and A2 Indicators: signalize the occurrence of alarm situation.

P Key: used to walk through the menu parameters.

▲ Increment key and ▼ - Decrement key: allow altering the values of the parameters.

◀ Back key: used to retrocede parameters.

OPERATION

When the controller is powered up, it displays its firmware version for 3 seconds, after which the controller starts normal operation. The value of PV and SP is then displayed and the outputs are enabled.

In order for the controller to operate properly in a process, its parameters need to be configured first, such that it can perform accordingly to the system requirements. The user must be aware of the importance of each parameter and for each one determine a valid condition.

The parameters are grouped in levels according to their functionality and operation easiness. The 5 levels of parameters are:

- 1 – Operation / 2 – Tuning / 3 – Alarms / 4 – Input / 5 – Calibration

The "P" key is used for accessing the parameters within a level.

Keeping the "P" key pressed, at every 2 seconds the controller jumps to the next level of parameters, showing the first parameter of each level:

PV >> Rtun >> FUR1 >> tYPE >> PRSS >> PV ...

To enter a particular level, simply release the “P” key when the first parameter in that level is displayed. To walk through the parameters in a level, press the “P” key with short strokes. To go back to the previous parameter in a cycle, press **◀**:

Each parameter is displayed with its prompt in the upper display and value/condition in the lower display. Depending on the level of parameter protection adopted, the parameter **PASS** precedes the first parameter in the level where the protection becomes active. See section **CONFIGURATION PROTECTION**.

DESCRIPTION OF THE PARAMETERS

OPERATION CYCLE

PV + SP	PV and SP indication – The upper display shows the current value of PV. The lower display shows the control SP value.
SPA1 SPA2	ALARM SETPOINT: Tripping point for alarm 1 and 2. Value that defines the point of activation for the programmed alarms with the functions Lo or Hi . For the alarms configured with Differential type functions, this parameter defines deviation (band). Not used for the other alarm functions.

TUNING CYCLE

Autun	AUTO-TUNE: enables the auto-tuning function for the PID parameters (Pb , Ir , dt). Defines the control strategy to be taken: oFF – Turned off. (no PID tuning) FRSt – FRSt automatic tuning. FULL – More accurate automatic tuning. Refer to the section DETERMINATION OF PID PARAMETERS for more details.
Pb	Proportional Band - Value of the term P of the control mode PID, in percentage of the maximum span of the input type. Adjust of between 0 and 500.0 %. When set to zero (0), control action is ON/OFF .
Ir	Integral Rate - Value of the term I of the PID algorithm, in repetitions per minute (Reset). Adjustable between 0 and 99.99. Displayed only if proportional band ≠ 0.
dt	Derivative Time - Value of the term D of the control mode PID, in seconds. Adjustable between 0 and 300.0 seconds. Displayed only if proportional band ≠ 0.
Ct	CYCLE TIME: Pulse Width Modulation (PWM) period in seconds. This term is not used when controller is set to ON/OFF action (Pb=0).
HYS	CONTROL HYSTERESIS: Is the hysteresis for ON/OFF control (set in temperature units). This parameter is only used when the controller is in ON/OFF mode (Pb=0).
Act	Action Control: rE Control with Reverse Action . Appropriate for heating . Turns control output on when PV is below SP. dIr Control with Direct Action . Appropriate for cooling . Turns control output on when PV is above SP.
SFS	SoftStart function – Time in seconds during which the controller limits the MV value progressively from 0 to 100 %. It is enabled at power up or when the control output is activated. If in doubt set SFS = 0 (the zero value disables the Soft start function).

Out1 Out2 Out3 Out4	Assign functions to the Output channels OUT1, OUT2, OUT3 e OUT4: oFF - Not used. CtrL - control output. A1 - alarm 1 output. A2 - alarm 2 output. A1A2 - Alarm 1 + Alarm2 (OR logic). Lbd - Loop Break Detect Alarm.
--	--

ALARMS CYCLE



FuA1 FuA2	Functions of Alarms. Defines the functions for the alarms among the options of the Table 02 .
SPA1 SPA2	ALARM SETPOINT: Tripping point for alarm 1 and 2. Value that defines the point of activation for the programmed alarms with the functions Lo or Hi . For the alarms configured with Differential type functions, this parameter defines deviation (band). Not used for the other alarm functions.
SP1E SP2E	Configures display of SPA1 and SPA2 also in the Operation Cycle. YES - SPA1/SPA2 are displayed in the Operation Cycle no - SPA1/SPA2 are not displayed in the Operation Cycle
bLA1 bLA2	Blocking Alarms. YES - enables initial blocking no - inhibits initial blocking
HYA1 HYA2	Alarm Hysteresis. Defines the difference between the value of PV at witch the alarm is triggered and the value at witch it is turned off.
FLSh	Allows visual signalization of an alarm occurrence by flashing the indication of PV in the operation level. YES - enables alarm signaling flashing PV no - disables alarm signaling flashing PV

INPUT CYCLE

tYPE	INPUT TYPE: Selects the input signal type to be connected to the process variable input. Refer to Table 01 for the available options.
FLtr	Digital Input Filter - Used to improve the stability of the measured signal (PV). Adjustable between 0 and 20. In 0 (zero) it means filter turned off and 20 means maximum filter. The higher the filter value, the slower is the response of the measured value.
dPPo	Selects the decimal point position to be viewed in both PV and SP.
un, t	Selects display indication for degrees Celsius or Fahrenheit: C - Indication in Celsius. F - Indication in Fahrenheit.
OFFS	SENSOR OFFSET: Offset value to be added to the PV reading to compensate sensor error. Default value: zero.
SPLL	Defines the SP lower limit of. To 50 mV input type sets the lower range for SP and PV indication.
SPHL	Defines the upper limit for adjustment of SP. To 50 mV input type sets the upper range for SP and PV indication.
Lbd	Time interval for the LBD function. Defines the maximum interval of time for the PV to react to a control command. In minutes.

IEou	Percentage output value that will be transfer to MV when the SAFE output function is enabled. If IEou = 0, the SAFE output function is disabled and the outputs are turned off in the occurrence of a sensor fail.
-------------	---

CALIBRATION CYCLE

All of the input and output types are calibrated in the factory. If a recalibration is required, this should be carried out by a experienced personnel. If this cycle is accidentally accessed, pass through all the parameters without pressing the  or  keys.

PRSS	<i>Password</i> . This parameter is presented before the protected cycles. See item Protection of Configuration.
CAL Ib	Enables or disables instrument calibration by the user, YES : shows calibration parameters no : Hides the calibration parameters.
InLC	<i>Input Low Calibration</i> . Enter the value corresponding to the low scale signal applied to the analog input.
InHC	<i>Input High Calibration</i> . Enter the value corresponding to the full scale signal applied to the analog input.
rStr	<i>Restore</i> . Restores the factory calibration for all inputs and outputs, disregarding modifications carried out by the user.
CJ	<i>Cold Junction</i> . This screen is for information purpose only.
PRSC	<i>Password Change</i> . Allows defining a new access password, always different from zero.
Prat	<i>Protection</i> . Sets up the Level of Protection. See Table 04 .
FrE9	Mains frequency. This parameter is important for proper noise filtering.

CONFIGURATION PROTECTION

The controller provides means for protecting the parameters configurations, not allowing modifications to the parameters values, avoiding tampering or improper manipulation. The parameter **Protection (Prat)**, in the Calibration level, determines the protection strategy, limiting the access to particular levels, as shown by the **Table 04**.

Protection Level	Protection Levels
1	Only the Calibration level is protected.
2	Calibration and Input levels.
3	Calibration, Input and Alarms levels.
4	Calibration, Input, Alarms and Tuning levels.
5	All levels are protected, but the SP screen in the operation level.
6	All levels are protected, including SP.

Table 04 – Levels of Protection for the Configuration

ACCESS PASSWORD

The protected levels, when accessed, request the user to provide the **Access Password** for granting permission to change the configuration of the parameters on these levels.

The prompt **PRSS** precedes the parameters on the protected levels. If no password is entered, the parameters of the protected levels can only be visualized.

The Access Password is defined by the user in the parameter *Password Change (PRSC)*, present in the Calibration Level. The factory default for the password code is 1111.

PROTECTION ACCESS PASSWORD

The protection system built into the controller blocks for 10 minutes the access to protected parameters after 5 consecutive frustrated attempts of guessing the correct password.

MASTER PASSWORD

The Master Password is intended for allowing the user to define a new password in the event of it being forgotten. The Master Password doesn't grant access to all parameters, only to the *Password Change* parameter (**PRSC**). After defining the new password, the protected parameters may be accessed (and modified) using this new password.

The master password is made up by the last three digits of the serial number of the controller **added** to the number 9000. As an example, for the equipment with serial number 07154321, the master password is 9 3 2 1.

Controller serial number is displayed by pressing  for 3 seconds.

DETERMINATION OF PID PARAMETERS

During the process of determining automatically the PID parameters, the system is controlled in **ON/OFF** in the programmed Setpoint. The auto-tuning process may take several minutes to be completed, depending on the system. The steps for executing the PID auto-tuning are:

- Select the process Setpoint.
- Enable auto-tuning at the parameter "**Autun**", selecting **FAST** or **FULL**.

The option **FAST** performs the tuning in the minimum possible time, while the option **FULL** gives priority to accuracy over the speed.

The sign TUNE remains lit during the whole tuning phase. The user must wait for the tuning to be completed before using the controller.

During auto tuning period the controller will impose oscillations to the process. PV will oscillate around the programmed set point and controller output will switch on and off many times.

If the tuning does not result in a satisfactory control, refer to **Table 05** for guidelines on how to correct the behavior of the process.

PARAMETER	VERIFIED PROBLEM	SOLUTION
Band Proportional	Slow answer	Decrease
	Great oscillation	Increase
Rate Integration	Slow answer	Increase
	Great oscillation	Decrease
Derivative Time	Slow answer or instability	Decrease
	Great oscillation	Increase

Table 05 - Guidance for manual adjustment of the PID parameters

For further details on PID tuning, visit our web site: www.novusautomation.co.uk

MAINTENANCE

PROBLEMS WITH THE CONTROLLER

Connection errors and inadequate programming are the most common errors found during the controller operation. A final revision may avoid loss of time and damages.

The controller displays some messages to help the user identify problems.

MESSAGE	DESCRIPTION OF THE PROBLEM
----	Open input. No sensor or signal.
Err 1 Err 6	Connection and/or configuration problems. Check the wiring and the configuration.

Other error messages may indicate hardware problems requiring maintenance service. When contacting the manufacturer, inform the instrument serial number, obtained by pressing the key  for more than 3 seconds.

PROCESS VARIABLE INPUT CALIBRATION

Visit our web site for further information www.novusautomation.co.uk

PART NUMBER FORMATION

N1040 – PR – F	Basic version; two outputs: OUT1= logical pulse / OUT2= relay - Wide input power range: 100 to 240 Vac 24 to 240 Vdc
N1040 – PRR	Three outputs: OUT1= logical pulse / OUT2 and OUT3 = relay
N1040 – PRRR	Four outputs: OUT1= logical pulse / OUT2, OUT3 and OUT4= relay

SPECIFICATIONS

DIMENSIONS: 48 x 48 x 80 mm
Approximate: 75 g
POWER SUPPLY: 100 to 240 Vac ($\pm 10\%$), 50/60 Hz
..... 48 to 240 Vdc ($\pm 10\%$)
..... 24 to 240 Vdc ($\pm 10\%$) for model N1040-PR-F
Maximum consumption: 6 VA

ENVIRONMENTAL CONDITIONS:

Operation Temperature: 0 to 50 °C
Relative Humidity: 80 % @ 30 °C
..... For temperatures above 30 °C, reduce 3 % for each °C
..... Internal use; Category of installation II, Degree of pollution 2;
altitude < 2000 meters

INPUT Thermocouples **J; K; T** and **Pt100** (according of **Table 01**)

Internal Resolution: 32767 levels (15 bits)
Resolution of Display: 12000 levels (from -1999 up to 9999)
Rate of input reading: up 55 per second
Precision: Thermocouples **J, K, T**: 0.25 % of the *span* ± 1 °C
..... Pt100: 0.2 % of the *span*
Input Impedance: Pt100 and thermocouples: > 10 M Ω
Measurement of Pt100: 3-wire type, ($\alpha=0.00385$)
With compensation for cable length, excitation current of 0.170 mA.

OUT1: Voltage pulse, 5 V / 25 mA

OUT2: Relay SPST; 1.5 A / 240 Vac / 30 Vdc

OUT3: Relay SPST; 1.5 A / 240 Vac / 30 Vdc

OUT4: Relay SPDT; 3 A / 240 Vac / 30 Vdc

FRONT PANEL: IP65, Polycarbonate (PC) UL94 V-2

ENCLOSURE: IP30, ABS+PC UL94 V-0

ELECTROMAGNETIC COMPATIBILITY: EN 61326-1:1997
and EN 61326-1/A1:1998

EMISSION: CISPR11/EN55011

IMMUNITY: EN61000-4-2, EN61000-4-3, EN61000-4-4,
EN61000-4-5, EN61000-4-6, EN61000-4-8 and EN61000-4-11

SAFETY: EN61010-1:1993 and EN61010-1/A2:1995

SPECIFIC CONNECTIONS FOR TYPE FORK TERMINALS;

PROGRAMABLE CYCLE OF PWM DE 0.5 UP 100 SECONDS;

STARTS UP OPERATION AFTER 3 SECONDS CONNECTED TO THE POWER SUPPLY.

CERTIFICATION: (CE)

SAFETY INFORMATION

Any control system design should take into account that any part of the system has the potential to fail. This product is not a protection or safety device and its alarms are not intended to protect against product failures. Independent safety devices should be always provided if personnel or property are at risk.

Product performance and specifications may be affected by its environment and installation. It's user's responsibility to assure proper grounding, shielding, cable routing and electrical noise filtering, in accordance with local regulations, EMC standards and good installation practices.

SUPPORT AND MAINTENANCE

This product contains no serviceable parts inside. Contact our local distributor in case you need authorized service. For troubleshooting, visit our FAQ at www.novusautomation.co.uk.

LIMITED WARRANTY AND LIMITATION OF LIABILITY

NOVUS warrants to the original purchaser that this product is free from defects in material and workmanship under normal use and service within one (1) year from the date of shipment from factory or from its official sales channel to the original purchaser.

NOVUS liability under this warranty shall not in any case exceed the cost of correcting defects in the product or of supplying replacement product as herein provided and upon the expiration of the warranty period all such liability shall terminate.

For complete information on warranty and liability limitations, check appropriate section in our web site: www.novusautomation.co.uk